

evoc

PROTECTIVE SPORTS PACKS



COLLECTION OVERVIEW
FY24

FY24



COVER: P: Manfred Stromberg R: Geoff Gulevich & Wolfgang Eyscholdt L: PERU

P
R
L

Manfred Stromberg
Geoff Gulevich
PERU

// EVOC FY24

Summer is coming - and it brings with it the new FY24 EVOC range with even more comfort and safety on the bike and all trails.

It all started with a backpack and an integrated protector. And what many at the time considered a quaint botch, is now the benchmark for protection, comfort and functionality in bike backpacks. However, this doesn't make us complacent, we have further improved on our areas of expertise in order to be able to offer more and more technologies from our in-house development. Here are just a few EVOC highlights for the FY24:

With the new TORSO PROTECTOR sporting the LITESHIELD FLEX protection technology, that we have presented in winter, we are offering a veritable game changer. It not only raises the bar in bike protection technologically, but what is equally important: it enormously improves comfort.

And it goes very well with the completely reengineered AIR FLOW CONTACT SYSTEM. The new back system is all about creating a really close fit while simultaneously allowing a maximum of ventilation. What sounds like two contradicting ideas initially has been further enhanced in the next iteration of this concept - and it's incorporated in several products.

We have also used our flow in order to revise one of our favorite products from the ground up - the TRAIL BUILDER 35.

Why are we putting all the effort in developing as much as possible by ourselves?

On the one hand the answer lies in our company's history: when there's nothing on the market that suits our demands. And on the other hand, because we can and it's enormous fun - a little more each year in fact!

We are looking forward to an ingenious season with you!

Your EVOC team

P
R
L

Manfred Stromberg
Kurt Sorge, Geoff Gulevich & Wolfgang Eysholdt
PERU



CONTENT

2	INTRODUCTION
8	HIGHLIGHT — AIR FLOW CONTACT SYSTEM
10	HIGHLIGHT — EXPLORER PRO 26
12	HIGHLIGHT — STAGE 12
14	HIGHLIGHT — HIP PACK PRO 3
18	FOCUSED — HYDRO PRO 6
20	FOCUSED — TRAIL BUILDER 35
22	PROTECTOR BACKPACKS
24	BACKPACKS
30	HIP PACKS
32	BIKE TRAVEL
38	BIKE PACKING
42	COMMUTING
44	TRAVEL
50	ACCESSORIES
56	SNOW INTRODUCTION
58	SNOW BACKPACKS
60	SNOW TRAVEL
62	QUALITY MADE
64	SIZE GUIDE
66	MATERIALS & SUSTAINABILITY
74	EVOC RETAIL PROGRAM
78	CORPORATE RESPONSIBILITY





HIGHLIGHT

PERFORMANCE AND COMFORT IN THE SPOTLIGHT

With its optimised design and the use of even higher-performance materials, the completely reengineered AIR FLOW CONTACT SYSTEM offers superior comfort in any situation.

It enables a snug, tight fit for a neutral load distribution and to provide stress relief for the shoulders, neck and back while riding. Simultaneously, this tight fit ensures there is no wobbling on the trail even in the tightest corners or the most gnarly sections. And to make sure the only thing that makes you break a sweat is the challenge of the trail itself, we have equipped it with the most effective ventilation system yet.



**AIR FLOW
CONTACT
SYSTEM**

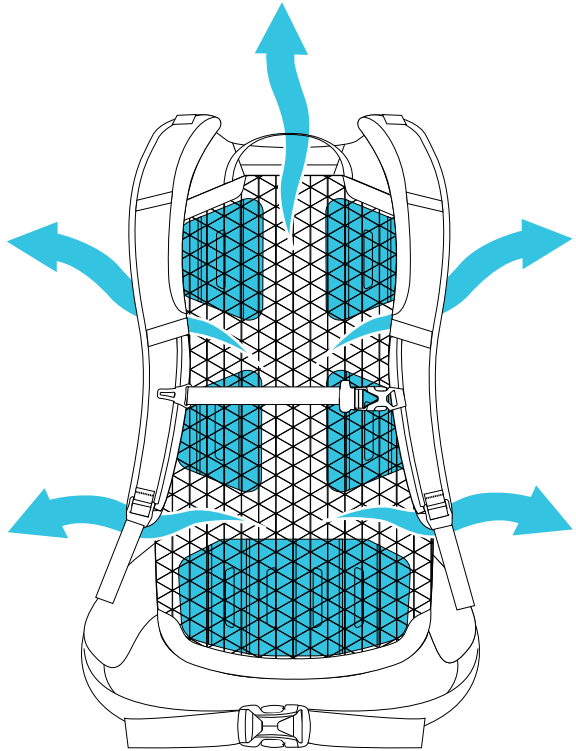



Wide ventilation channels between the strategically positioned EVA foam pads and a coarser, but highly robust and comfortable mesh ensure noticeable air circulation.

The heart of the back section is the 3D molded stabiliser. The preformed ribs provide the necessary stability to avoid buckling while specifically positioned flex areas ensure that the backpack adapts ergonomically to the back itself and to any movement.

EXPLORER PRO 26

FEATURE-LADEN BIKE ADVENTURE PACK

Made for large-scale bike tours, the new EXPLORER PRO 26 enables you to carry loads of luggage as comfortably and securely as possible on your body while simultaneously sporting the best ventilation system we have ever conceived.

We've kept the elaborate compartment management, but optimised the carrying comfort of every other facet imaginable. Seams, materials, ergonomics, you name it.



QUICKLY ACCESSIBLE
TOOL COMPARTMENT



BRACE LINK AND
OPTIMISED SEAMS ON
SHOULDER STRAPS



INCLUDING SEPARATE
WASH POUCH

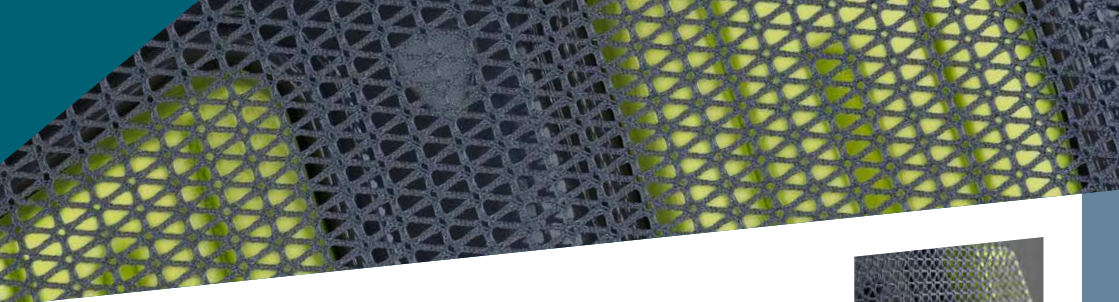

HYDRATION SYSTEM COMPARTMENT
for bladders with 1.5 to 3l



Neutral load distribution
with BODY HUGGING

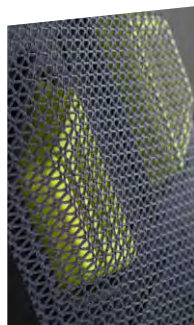

NEW
AIR FLOW CONTACT SYSTEM
with improved ergonomics
and ventilation system

EXTRA WIDE HIP WINGS
with big, zippered pockets



AIRO FLEX hip belt for ventilated
yet stable load transmission to hips



**AIR FLOW
CONTACT
SYSTEM**

STAGE 12

LIGHTWEIGHT PERFORMANCE BACKPACK WITH FOCUS ON UNRELENTING FIT AND HEAT REDUCTION.

With its updated AIR FLOW CONTACT SYSTEM, the new STAGE 12 ensures ideal weight distribution, as well as supreme ventilation, to make overheating one less issue.

The pack sits perfectly close to the body to avoid sketchy load shifts when the focus needs to be on the trail ahead. Fit and comfort have been further enhanced through better integration of the BRACE LINK and thoroughly re-designed seamless shoulder straps among many other details.



HELMET HOLDER



BRACE LINK AND OPTIMISED SEAMS ON SHOULDER STRAPS



TOOL COMPARTMENT CAN BE OPENED AND CLOSED WITH ONE HAND, EVEN WITH GLOVES

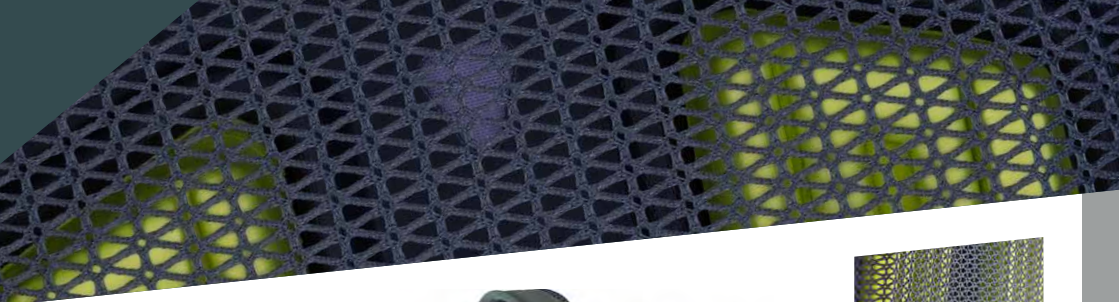

HYDRATION SYSTEM
COMPARTMENT for
bladders up to 2l

PFC-free finishing

AIRO FLEX hip belt for ventilated
yet stable load transmission to hips



Elastic side pocket



NEW
AIR FLOW CONTACT SYSTEM
with improved ergonomics
and ventilation system



**AIR FLOW
CONTACT
SYSTEM**

HIGHLIGHT // HIP PACKS

HIP PACK PRO 3

CARRYING ESSENTIALS WITH UNPARALLELED FREEDOM OF MOVEMENT

The HIP PACK PRO 3 is the most unrestrictive way to bring tools, provisions, rain jacket, etc. on your rides. The wide hip wings with zippered pockets, the perforated, comfortable AIRO FLEX belt and the improved AIR FLOW CONTACT SYSTEM

ensure you hardly notice you're wearing it. The exclusive VENTI FLAP feature enhances ventilation uphill and ensures an even firmer fit downhill. It's compatible with 1.5l hydration systems but also sports a bottle holder.



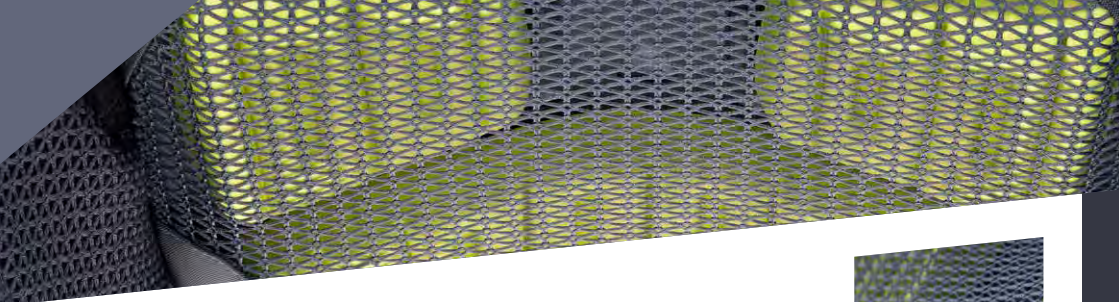

AIRO FLEX hip belt for ventilated
yet stable load transmission to hips

Extra wide hip
wings with
improved
ergonomic
fit

VENTI FLAP
for separate uphill
and downhill modes

Quick-access TOOL COMPARTMENT

PFC-free finishing

HYDRATION SYSTEM COMPARTMENT
for 1.5l bladders

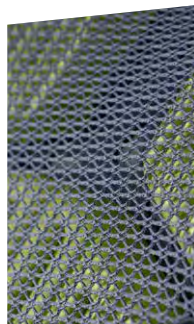

NEW
AIR FLOW CONTACT SYSTEM
with improved ergonomics
and ventilation system



**AIR FLOW
CONTACT
SYSTEM**





FOCUSED



STAY LIGHT AND KEEP HYDRATED!

Developed for high-performance settings, the extra lightweight hydration backpack stores all your essentials without you even feeling you are wearing it. Its carrying system and low-profile pack make it fit like a glove while simultaneously offering a high degree of ventilation. Sitting on the upper back, it provides freedom of movement and access to jersey pockets. Despite the ultra-slim profile, it offers space for a hydration bladder, as well as bars, gels, phone, keys and even a rain jacket. The volume can be reduced efficiently by means of specific compression straps.



RECYCLED NYLON
TAFFETA WITH PFC-FREE
FINISHING



MAGNETIC HYDRATION
HOSE CLIP



CLOSE-TO-BODY VEST-
PACK CONSTRUCTION



1.5l HYDRATION BLADDER included

Compression straps for slim profile

Lateral quick access



2 nutrition compartments for bars or gels

Two chest strap pockets for quick access to gear you need while riding



HYDRO PRO SERIES // HYDRO PRO 1.5, HYDRO PRO 3 & HYDRO PRO 6

BACKPACKS // TRAIL BUILDER 35

FOCUSED



No matter if it's a secret gem or your favourite run at a big bike park - one thing that most trails have in common: someone has put a lot of sweat and tears and even more heart into them. And in order to make life easier for these unsung heroes, we have completely revamped one of our classics, the TRAIL BUILDER. The new TRAIL BUILDER 35 offers even more comfort, supreme organisation and attachment of tools, plus we even managed to make it lighter and more robust.

The TRAIL BUILDER 35 is a highly sophisticated backpack for transporting tools safely —a mobile trail building station that we have developed in collaboration with the builders themselves.



DETACHABLE NAIL WRAP WITH 5.2L OF VOLUME FOR CARRYING NAILS, SCREWS, BOLTS, ETC.



PERFECT FIT AND HIGH DEGREE OF COMFORT EVEN UNDER HIGH LOADS



DETACHABLE RAIN COVER IN SIGNAL ORANGE WITH TRAIL BUILDER PRINT



Ergonomically formed, comfortably padded shoulder straps for extra heavy weights

Extremely durable, cut and tear-resistant US Cordura 1000 D-material with sturdy aluminium buckles

Extra-wide hip wings with pockets and adjustable belt for extra heavy weights



The numerous smart compartments facilitate supreme organisation

Multi-functional attachment system for safely and reliably transporting chain saw, rake, pickax, bucket, etc.

TRAIL PRO 26

liteshield
BACK PROTECTOR



**BLACK -
CARBON GREY**

EV100117128SM
EV100117128LXL



TRAIL PRO 16

liteshield
BACK PROTECTOR



DENIM

EV100118236SM
EV100118236LXL

NEW COLOUR



TRAIL PRO 10

liteshield
BACK PROTECTOR



CURRY - DENIM

EV100119612SM
EV100119612LXL



TRAIL PRO SF 12

liteshield
BACK PROTECTOR



MULTICOLOUR

EV100122901XS



XS SIZE

FR ENDURO BLACKLINE 16

liteshield
BACK PROTECTOR



BLACK

EV100106100S
EV100106100ML
EV100106100XL



FR LITE RACE 10

liteshield
BACK PROTECTOR



**CARBON GREY -
BLACK**

EV100115123S
EV100115123ML

NEW COLOUR



FR ENDURO E-RIDE 16

liteshield
BACK PROTECTOR



**STONE - BRIGHT
ORANGE**

EV100121132ML





P
R
L

Manfred Stromberg
Wolfgang Eyeholdt
PERU

STAGE 18



STONE

EV100214107

STAGE 12



DARK OLIVE

EV100215332

STAGE 6



STONE - STEEL

EV100217138*

* HYDRATION BLADDER 2 included

EXPLORER PRO 26



STEEL

EV100213131

JOYRIDE 4



SILVER - CARBON GREY

EV100317127

RIDE 16



MULTICOLOUR
EV100320901



**LIGHT OLIVE -
OLIVE**
EV100320303

RIDE 12



**DARK OLIVE -
BLACK**
EV100323331*



**CHILI RED -
CARBON GREY**
EV100323514*

RIDE 8



OCEAN
EV100324237*



BLACK
EV100324100*

HYDRO PRO 6
+ HYDRATION BLADDER 1.5



STONE
EV100428107



HYDRATION
BLADDER 1.5
INCLUDED

HYDRO PRO 3
+1.5L HYDRATION BLADDER



BLACK
EV100326100



HYDRATION
BLADDER 1.5
INCLUDED

HYDRO PRO 1.5
+1.5L HYDRATION BLADDER



STEEL
EV100327131



HYDRATION
BLADDER 1.5
INCLUDED

TRAIL BUILDER 35



BLACK
EV101301100

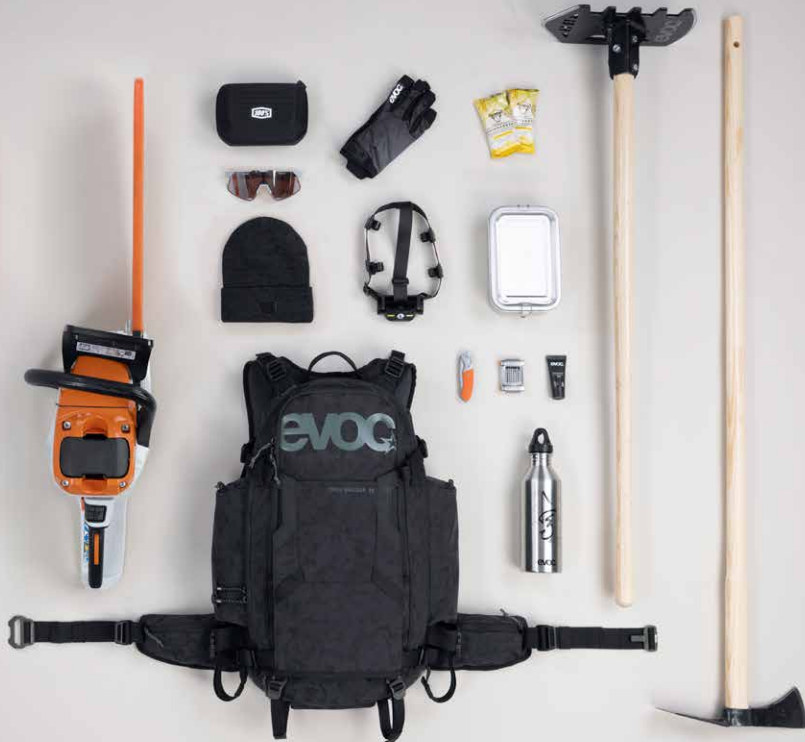





HIP POUCH



BLACK
EV102505100

HIP PACK PRO 3



BLACK
EV102612100
EV102613100*

*Optional: HIP PACK HYDRATION BLADDER 1.5 included

HIP PACK 3



BLACK
EV102507100
EV102506100*

*Optional: HIP PACK HYDRATION BLADDER 1.5 included

HIP POUCH PRO + DRINK BOTTLE 0,55



BLACK
EV102510100

P
R
L

Stefan Neuhauser
Daniel Schäfer
KOS/GRC

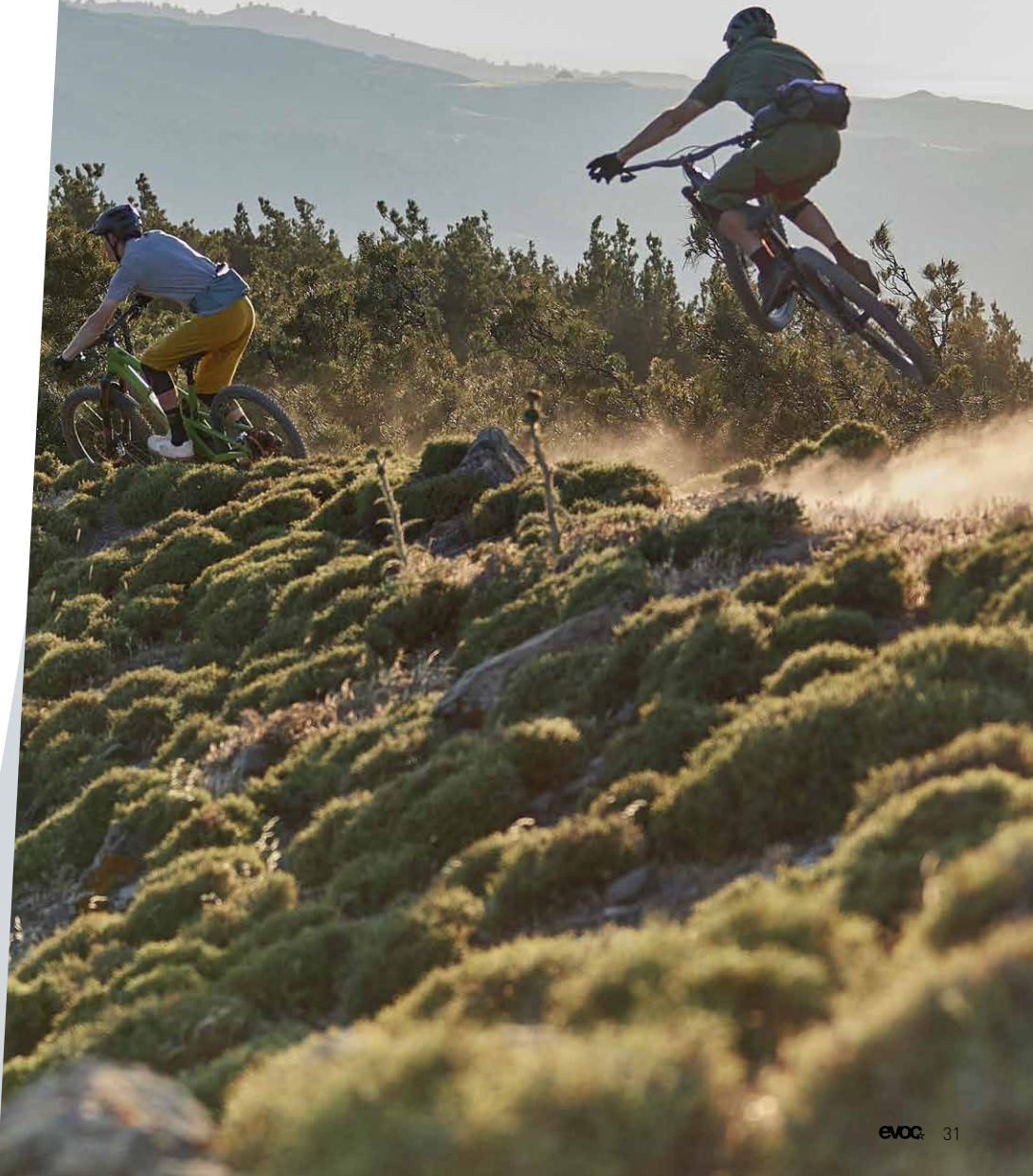

ROAD BIKE BAG PRO

UPDATED



BLACK
EV100409100

BIKE BAG PRO



MULTICOLOUR
EV100410901

BLACK
EV100410100

BIKE BAG



BLACK
EV100411100

BIKE TRAVEL BAG XL



OLIVE
EV100405307

BMX TRAVEL BAG



BLACK
EV100403100

CHAIN COVER ROAD



BLACK
EV100518100

CHAIN COVER MTB



BLACK
EV100519100

BIKE STAND PRO



BLACK
EV100528100

CLIP ON WHEEL 1-PIN VERSION (> 2019) CLIP ON WHEEL 2-PIN VERSION (< 2018)



1-PIN / BLACK
EV900209100



2-PIN / BLACK
EV902302100

FRAME PAD



BLACK
EV100515100

TAILGATE PAD DUO



BLACK
EV100520100

TAILGATE PAD



BLACK
EV100527100ML
EV100527100XL

TAILGATE PAD CURVE



BLACK
EV100535100ML
EV100535100XL

TAILGATE PAD STRAP E-RIDE
(2-pcs set)

BLACK
EV100529100

MTB WHEEL BAG (2-pcs set)



BLACK
EV100522100

TWO WHEEL BAG



BLACK
EV100523100

PROTECTIVE BIKE RUG



BLACK
EV100524100

BIKE RACK COVER MTB



BLACK
EV100533100

BIKE RACK COVER ROAD



BLACK
EV100532100



SEAT PACK WP 2



STEEL

EV100608131

SEAT BAG



STEEL

EV100605131S

EV100605131M

SEAT BAG TOUR



STEEL

EV100606131M

EV100606131L

SEAT PACK BOA® WP 6



STEEL
EV100610131

SEAT PACK BOA® WP 8



STEEL
EV100611131

SEAT PACK BOA® WP 12



STEEL
EV100612131

SEAT PACK BOA® WP 16



STEEL
EV100613131



TOP TUBE PACK WP



STEEL

EV102805131

MULTI FRAME PACK WP S



STEEL

EV102806131-S

MULTI FRAME PACK WP M



STEEL

EV102806131-M

FRAME PACK WP S



STEEL

EV102807131-S

FRAME PACK WP M



STEEL

EV102807131-M

HANDLEBAR PACK WP 1.5



STEEL

EV102811131

HANDLEBAR PACK BOA® WP 5



STEEL

EV102810131

HANDLEBAR PACK BOA® WP 9



STEEL

EV102812131



COMMUTE PRO 22

It'shield[®]
BACK PROTECTOR



BLACK

EV450102100SM

EV450102100LXL

COMMUTE 22



BLACK

EV450201100

P
R
L

Baschi Bender
Sarah Bergler
MUNICH/GER



WORLD TRAVELLER 125



BLACK
EV401215100



MULTICOLOUR
EV401215901

TERMINAL BAG 40+20



BLACK
EV401216100



MULTICOLOUR
EV401216901



MISSION PRO 28



MULTICOLOUR
EV401308901



STEEL
EV401308131

WASH BAG



MULTICOLOUR
EV401218901



BLACK
EV401218100



P Philipp Herfort
R Julia Schäfer, Daniel Schäfer
L & Holger Feist
ZITTAUER GEBIRGE/GER

DUFFLE BAG 100

NEW COLOUR



DARK OLIVE -

BLACK

EV401219331

DUFFLE BAG 60



DARK OLIVE -

BLACK

EV401220331

NEW COLOUR



CURRY - BLACK

EV401220610

DUFFLE BAG 40

NEW COLOUR



CARBON GREY -

BLACK

EV401221123

DUFFLE BACKPACK 26



**CARBON GREY -
BLACK**
EV401311123

NEW COLOUR



**DARK OLIVE -
BLACK**
EV401311331

DUFFLE BACKPACK 16

NEW COLOUR



**DARK OLIVE -
BLACK**
EV401312331



**CARBON GREY -
BLACK**
EV401312123

GEAR BAG 20



BLACK
EV401408100

GEAR BAG 35



BLACK
EV401407100

GEAR BAG 55



BLACK
EV401406100

GEAR BACKPACK 60



BLACK
EV401314100

GEAR BACKPACK 90



BLACK
EV401313100

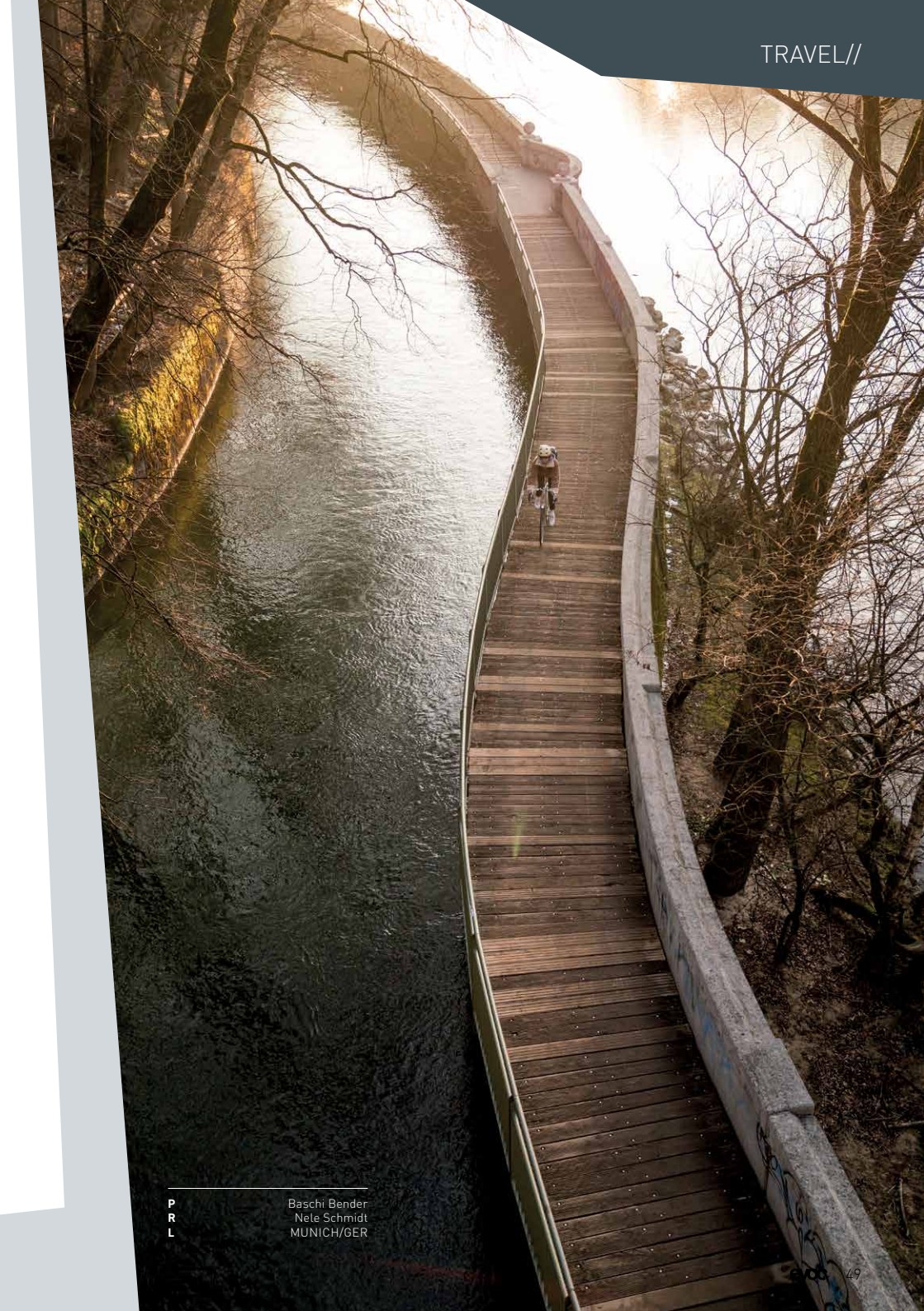

P
R
L

Baschi Bender
Nele Schmidt
MUNICH/GER

HELMET HOLDER



BLACK
EV601008100

CARGO STRAPS (2-pcs set)



BLACK
EV602301100

DRINK BOTTLE 0.55



MULTICOLOUR
EV601117901

DRINK BOTTLE 0.75



MULTICOLOUR
EV601118901

STAINLESS STEEL BOTTLE 0.75



SILVER
EV601119136

**HIP PACK HYDRATION
BLADDER 1.5**



CARBON GREY
EV601113121

HYDRATION BLADDER 1.5/2/3



CARBON GREY
EV601116121
EV601111121
EV601110121

**HYDRATION BLADDER 2
INSULATED**



CARBON GREY
EV601112121

HYDRATION TUBE



CARBON GREY
EV901104121

MAGNETIC TUBE CLIP



BLACK
EV901101100

BLASTER BITE VALVE



BLACK
EV901103100

P
R
L

Manfred Stromberg
Geoff Gulevich & Wolfgang Eysholdt
PERU









P
R
L

Syo van Vliet
Paddy Graham
SONNENKOPF/AUT

SNOW FY24



P
R
L

Sjo van Vliet
Paddy Graham
SONNENKOPFAUT

// NEW CHAPTER OF SNOW PROTECTION FOR EVOC

Winter sports, or more specifically freeride snowboarding, is one of the main reasons why EVOC exists. A serious crash during a snowboard video shoot got us thinking about how we could offer greater protection against back injuries. The result was the first-ever EVOC backpack with integrated back protection!

What started as a makeshift solution has now turned into CE-certified, high-end protective equipment, and our protector backpacks are considered a global benchmark for protection, comfort, and functionality.

We not only work with recycled materials, but also use resource-efficient technologies, such as yarns made with used coffee grounds, and try to make our products as recyclable as possible. With the LITE series, we've even managed to create a product which is almost completely recyclable. But that's just the beginning!

We're looking forward to a great winter season with you!

LINE PRO 20



liteshield
BACK PROTECTOR



DENIM

EV200216236SM

EV200216236LXL

LINE 30



SILVER -

HEATHER

CARBON GREY

EV200213127

LINE 20



SILVER -

HEATHER

CARBON GREY

EV200214127



SNOW GEAR ROLLER



BLACK

EV200814100L

EV200814100XL

SKI ROLLER



BLACK

EV200815100XL

EV200815100L

P
R
L

Philipp Herfort
Holger Feist
BAKHMARO/GE0

BOARD BAG



STEEL

EV200812131

SKI BAG



STEEL

EV200811131



QUALITY MADE//

ENGINEERED IN GERMANY

All EVOC products are engineered in Germany to ensure the highest standards of performance, durability and quality.

PRODUCTION FACILITIES

Our products are made exclusively by handpicked manufacturers with a long-term reputation for delivering quality consistently. We ensure the quality of our products through regular on site visits and stringent quality control.

are also tested by world-class athletes who take our products to the limit.

The constant testing and resulting feedback ensure that every feature of an EVOC product has been refined to perfection by the time you hold it in your hands.

MATERIALS

All the materials we employ are precisely adapted to the specific requirements of each individual product and its range of use. Functionality, protection and durability are parameters that play a decisive role in our selection.

We work with the best suppliers worldwide and only purchase the highest-quality materials. If materials or components do not meet our expectations, we develop them ourselves.

EXPERIENCE AND FEEDBACK

Our staff of former professional athletes and ambitious riders with strong roots in biking and snow sports, has long-standing experience in manufacturing sports equipment and constantly use our equipment around the world. Every season our products

PLAN
REVISE
IMPROVE
REALISE





SIZE GUIDE // PROTECTOR BACKPACKS & BACKPACKS

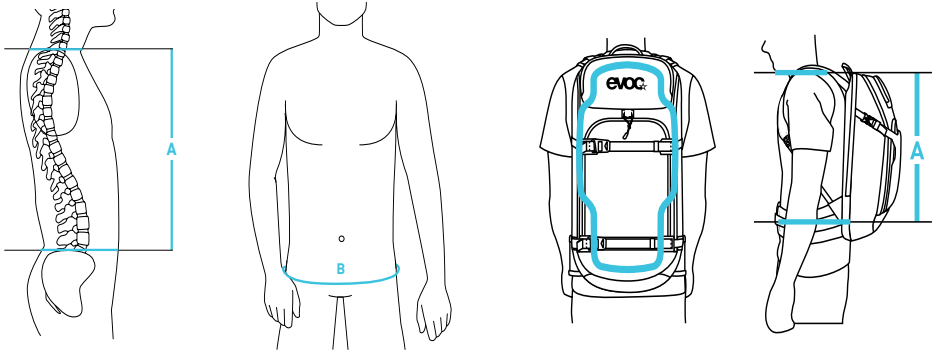

TORSO LENGTH **A** is critical for ensuring optimal protection and fit. To determine it, use a measuring tape and measure from the top of your hip bone to the tip of your shoulder. To determine your HIP BELT LENGTH **B**, measure your hip circumference.

FR SERIES // LINE R.A.S. PROTECTOR (M/L)

SIZE	A // TORSO LENGTH	B // HIP BELT LENGTH
S	38 - 42 cm	76 - 105 cm (flex)
M/L	44 - 48 cm	84 - 115 cm (flex)
XL	49 - 53 cm	88 - 117 cm (flex)

EXPLORER PRO

SIZE	A // TORSO LENGTH	HIP CIRCUMFERENCE
S	38 - 43 cm	76 - 115 cm (flex)
M/L	44 - 56 cm	76 - 115 cm (flex)

TRAIL PRO, TRAIL PRO SF (XS) & NEO // LINE PRO

SIZE	A // TORSO LENGTH	B // HIP BELT LENGTH
XS	33 - 37 cm	70 - 100 cm (flex)
S/M	43 - 47 cm	76 - 118 cm (flex)
L/XL	48 - 52 cm	84 - 122 cm (flex)

EXPLORER PRO 26, EXPLORER PRO 30

SIZE	A // TORSO LENGTH	B // HIP BELT LENGTH
26 (S)	36 - 42 cm	75 - 125 cm (flex)
30 (M/L)	43 - 52 cm	75 - 125 cm (flex)

SIZE GUIDE // PROTECTION WEAR & TEAM WEAR

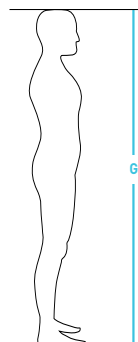
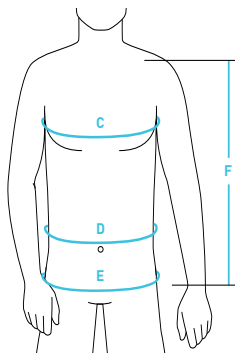

To determine your **CHEST CIRCUMFERENCE C**, use a measuring tape and measure from under your armpits around your chest. To determine your **WAIST D**, measure around your waist where you have your belly button. To determine your **HIP CIRCUMFERENCE E**, measure around your hip. For your **ARM LENGTH F**, measure from your shoulder tip to your wrist with the arm slightly bent.

To determine your **BODY HEIGHT G**, measure your full length from the floor up without shoes.

MEN

SIZE	C // CHEST CIRCUMFERENCE	D // WAIST CIRCUMFERENCE	E // HIP CIRCUMFERENCE	F // ARM LENGTH	G // BODY HEIGHT
S 44/46	87 - 94,5 cm	76 - 82 cm	92 - 97 cm	60 - 62,5 cm	168 - 172 cm
M 48/50	94,5 - 102 cm	82 - 88 cm	97 - 105 cm	62,5 - 64,5 cm	172 - 178 cm
L 52/54	102 - 109 cm	90 - 98 cm	105 - 111 cm	64,5 - 67 cm	178 - 183 cm
XL 56/58	109 - 118 cm	99 - 110 cm	111 - 120 cm	67 - 69 cm	183 - 186 cm

WOMEN

SIZE	C // CHEST CIRCUMFERENCE	D // WAIST CIRCUMFERENCE	E // HIP CIRCUMFERENCE	F // ARM LENGTH	G // BODY HEIGHT
S 34/36	84 - 88 cm	62 - 71 cm	85 - 96 cm	59 cm	165 - 168 cm
M 38/40	87 - 95 cm	71 - 78 cm	96 - 102 cm	60 cm	168 - 170 cm
L 42/44	95 - 102 cm	79 - 86 cm	102 - 109 cm	61 cm	> 170 cm

KIDS

SIZE	C // CHEST CIRCUMFERENCE	D // WAIST CIRCUMFERENCE	E // HIP CIRCUMFERENCE	G // BODY HEIGHT
JS	62 - 67 cm	60 - 67 cm	65 - 71 cm	122 - 130 cm
JM	66 - 74 cm	64 - 74 cm	70 - 79 cm	130 - 143 cm
JL	74 - 85 cm	66 - 77 cm	79 - 90 cm	143 - 164 cm

MATERIALS//

We carefully select materials for our products or tailor them to our exact specifications.

We make sure that all of our products are lightweight and made of the best possible materials to ensure the utmost functionality and quality.

OUTER MATERIALS

The best backpacks and bags are durable, abrasion-resistant, lightweight, and waterproof (or water-resistant). We use various types of fabrics with different weaves and thicknesses that optimally support the specific function of each product.

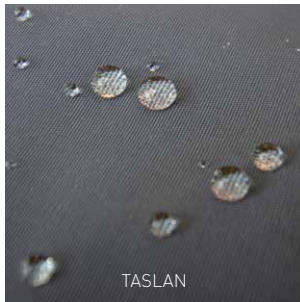

Our high-end fabric, that sports an excellent low weight/stability ratio. Thanks to its special weave using thick and thin yarn, it is particularly tear-resistant and retains its shape, while the PU coating makes it completely waterproof.

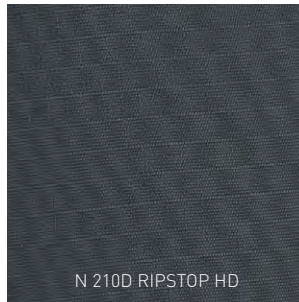

This high-density nylon fabric with ripstop construction is extremely lightweight, abrasion-resistant, and incredibly tear-resistant. The crosshatch weave pattern ensures that potential tears do not spread. Water-repellent coating.



Extremely abrasion resistant yet super lightweight, this high-quality nylon-polyester mix with PU coating on the inside endures even the harshest abuse yet feels soft to the touch and has a slick matte look.

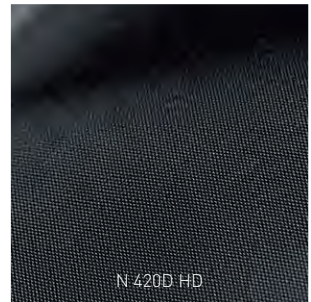

This nylon is ideal for use whenever a high degree of durability and abrasion resistance is required. The robust, high-quality fabric is remarkably lightweight and finished with a water-resistant inner coating.



N 100D SHADOW BOX

Our lightest fabric for all backpacks that need to be lightweight. The extremely tear-resistant relief-like structure is a result of how it is woven. The PU coating makes it water-resistant.



TAFFETA

We use this light, durable and completely waterproof fabric for our rain covers, in particular.

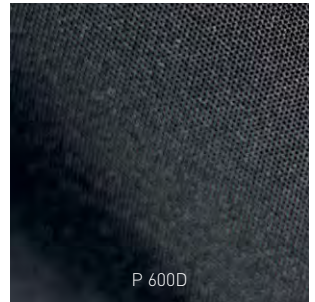

P 600D

Where usage involves high wear and tear, such as with bag bases or BIKE BAGS, we use this tear-resistant and lightweight polyester fabric. Water-repellent finish and even dirt simply rolls off the fabric.



US 1000D CORDURA

This exceptionally strong cordura fabric is practically indestructible. What really sets this material apart is its durability and protection, but it also scores high points for its low weight. Water-repellent thanks to a special coating.

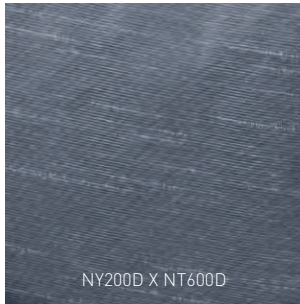

NY200D X NT600D

This extremely robust, abrasion-resistant, 100% waterproof outer material made from a nylon-polyester mix (71% nylon, 29% polyester) also comes with PU and TPU coating, which makes it the perfect choice for products which will see high wear and tear, such as our BIKE PACKING bags.



N6 420D R/S

The lightweight yet incredibly durable and abrasion-resistant Polyamid textile made of high-end Nylon 6 fibers can take the hardest abuse and is therefore used in our photo range. Thanks to the 5mm Ripstop webbing it is specifically tear-resistant. Water-repellent and PFC-free.

MATERIALS//SUSTAINABILITY

ECO-FRIENDLY MATERIALS

An important pillar in the process of reducing our environmental footprint is the use of sustainable materials. In doing so, we research and work with the best and most innovative suppliers worldwide to find materials that meet our high quality standards while being more resource-efficient and environmentally friendly.

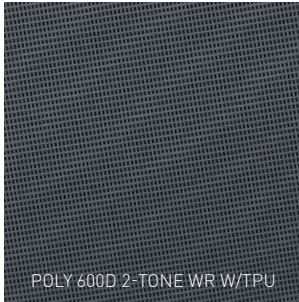

For our heavy-duty EVOG products, we use this TPU-coated fabric. It is relatively light, extremely temperature-resistant, and completely water-proof. That makes it perfect to withstand all the knocks and scrapes that come with travelling. And the best: It is 100 % free of PVCs and PFCs.



Our most resource-efficient and energy-conserving outer material: The Polyester is made entirely from recycled, pre-consumer waste and scores with its nice and silky touch while being utterly robust and durable. Finished with a high-quality PU-coating, making it dirt and water-repellent.



MIPAN® regen is a GRS certified, regenerated nylon yarn that we use for the fast-drying, highly breathable, high-performance functional material of our PROTECTOR VEST PRO. It's made from 100% recycled production waste from chip manufacturing, thereby saving valuable resources.



A functional polyester fabric that is fast-drying, highly breathable, and flexible. Thanks to its water and energy-saving production process, it has a significantly lower environmental footprint than similar textiles. Moreover, the bluesign® certified fabric is recyclable because its elasticity is achieved mechanically rather than through the use of elastane. Finished with the odour-neutralising S.Café® technology that is also eco-friendly.



An especially resource-efficient and highly functional yarn. In a patented, energy-saving process, coffee grounds are fused with recycled PET at low temperatures and high pressure. The yarn is transformed into a moisture-absorbing, fast-drying polyester fabric that provides excellent odour control. It can be recycled and is solution-dyed and bluesign®, OEKO-TEX®, Cradle to Cradle®, and GRS certified.



Our recycled taffeta is waterproof, lightweight, and truly durable. Moreover, it's PFC-free.

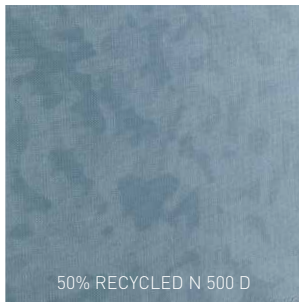

Very comfortable to the touch thanks to the special surface treatment (peaching), this material also displays a high degree of durability and abrasion resistance. 50% recycled Polyamid and water-resistant with a water column of 1,500 mm thanks to the PU coating and PFC-free finish.



TREATMENTS & FINISHES

In addition to textiles made from S.Café® yarn, we use a finish with S.Café® technology on other fabrics to neutralise unpleasant odours. Coffee grounds have numerous microscopic pores that absorb odours in a chemical-free, long-lasting way. For this purpose, an extract is obtained from used coffee grounds from local cafés in a patented process that exploits precisely this natural, odour-absorbing ability and can then be used in textiles.



MATERIALS//

FINISHING MATERIALS



During exercise, heat is generated, which should be wicked away from the body through appropriate ventilation. Depending on the scope of application, we use different, highly efficient mesh fabrics that ensure maximum air circulation, yet do not absorb moisture:

AIR MESH

3D AIR MESH

HONEYCOMB MESH



Neoprene exhibits flexibility and stability at the same time, and therefore offers exceptionally good grip – over a wide temperature range, and in wet and dry conditions. We use it for our lightweight SKI and BOARD COVERS.



With its origin in medical device technology, this extremely sturdy premium material has everything to justify its use in our top-quality hip belts: exceptionally flexible, completely air-permeable, and yet sufficiently sturdy to keep the backpack in place with the load as close as possible to the body's centre of gravity.

TREATMENTS & FINISHES

Our materials are finished with high-quality coatings that extend their lifespan and enhance the quality of our products. The coatings used on our lightweight outer materials provide protection from dirt and stains and prevent moisture from penetrating.

PU COATING

TEFLON COATING

DURABLE WATER REPELLENCY



POLYGIENE ODORCRUNCH™

Natural, silica-based odour absorbing technology that keeps fabrics smell fresh for longer and reduces the amount of washing required.



POLYGIENE STAYFRESH™

Antibacterial, freshness technology that is embedded in textiles and inhibits the growth of odour-causing bacteria, so garments need less washing, saving water, energy and wear and tear.

LININGS

By linings we mean our lining and inner materials that are used in our bags and backpacks. We vary these, too, according to the intended use for the bag or backpack, and ensure they are colour-coordinated so that the design experience can continue to be appreciated once they are opened up.



Our TRAVEL Line linings are soft and silky to touch and hold their shape well thanks to the fine web structure of the fabric. Ideal protection for clothing and personal equipment. The extra coating ensures it is robust enough for sports travel, too.



A very soft, velvety and padded 3-layered material. It protects sensitive contents and is therefore used in the laptop compartment of our MISSION PRO.



Particularly robust and with an extra coating for enhanced resistance to wear and tear, our first choice for tool, hydration bladder and avalanche compartments and the like.

FEATURES & ACCESSORIES

For our products, we only use premium accessories that support their function and add design value. If we cannot find the right accessories for our equipment, we simply develop them ourselves in order to optimally satisfy our expectations.

YKK PLASTIC ADD-ON PARTS AND ZIPPERS

WOOJIN PLASTIC ADD-ON PARTS

HYPALON ZIPPER GARAGES

NON-STICK VELCRO

EVA TARPAULIN MESH (PVC-FREE)

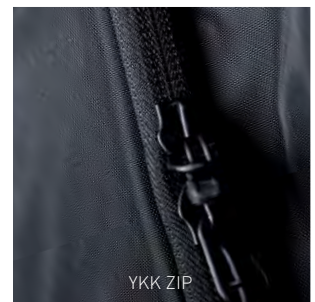

PROTECTOR MATERIALS



liteshield
BACK PROTECTOR

Originally used in motorcycling, this segmented EPS layer construction is characterised by maximum shock absorption values, extremely low weight and complete temperature insensitivity. TÜV/GS-certified.



liteshield ^{plus}
BACK PROTECTOR

Innovative, extremely light, flexible and non-temperature-sensitive back protector. The 2-component sandwich construction made of highly-compressed EPP foam offers excellent impact protection and adapts to every movement with its plus-shaped segments. CE-certified to EN 1621-2, level 2.





evoc

evoc

evoc



//EVOC RETAIL PROGRAM



Today, retail is facing completely new challenges.

What consumers expect from brick and mortar shops is a great variety of products and immediate availability. An optimal product presentation and pleasant shopping environment help the customer to make a good purchase decision.

Consistent communication and brand message give the buyer a feeling of safety when buying a high quality product.

This is why EVOC offers retailers a specific retail program, including sales promotion concepts and measurements. Adding to the program offer are presentation aids, displays, and sales tools.

EVOC PARTNER STORE//

The EVOC Retail Program is offering a wide range of individual solutions for brand communication and product presentation.

The beautiful display system has been developed in-house and is supporting your shop design and visual merchandising.

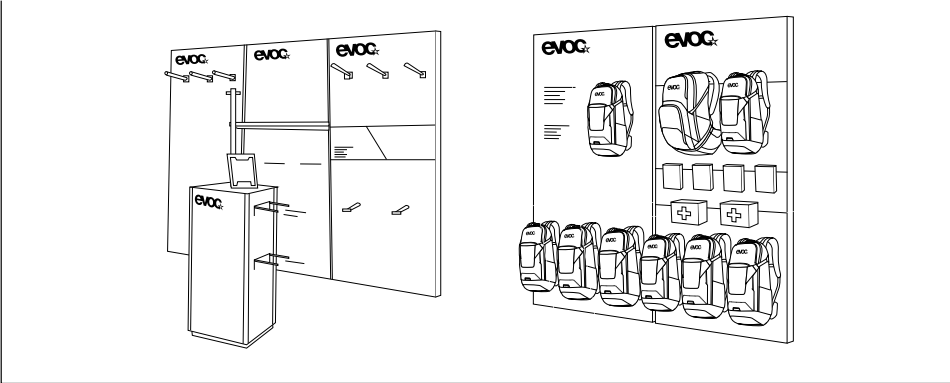
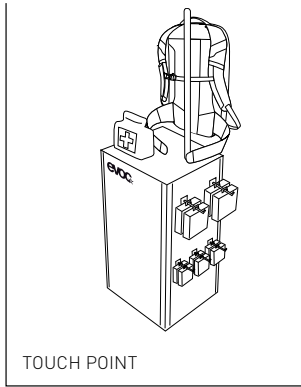
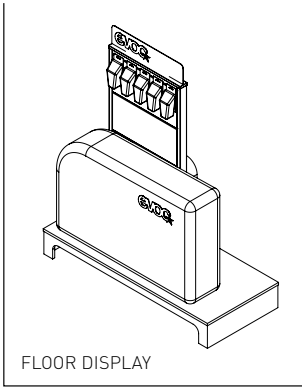



PROTECT THE THINGS YOU LOVE

OUR MISSION

EVOC stands for evolution and the concept of high-quality, sports backpacks, bags, and luggage with a particular focus on proper protection of rider and gear.

For us, sport and travel mean adventure, unique experiences, and a good time with friends. Our products are always a little more than just items of equipment.

For us, "Protect the things you love" not only means doing everything possible to protect you and your equipment, but also the nature in which we love roaming.

OUR GOAL IS TO CREATE A COMMUNITY WITHIN WHICH ALL EMPLOYEES, PARTNERS, PRODUCERS, AND CUSTOMERS WANT TO SHARE THIS APPROACH WITH US.

IN DOING SO, WE DO NOT ONLY FOCUS ON DEVELOPING INNOVATIVE PRODUCTS THAT CONSERVE RESOURCES AS MUCH AS POSSIBLE. WE ALSO TAKE SOCIAL RESPONSIBILITY, PROMOTE PARTNERSHIPS, LIVE AN OPEN AND HONEST COMMUNICATION, AND ARE ALWAYS STRIVING TO FURTHER IMPROVE OUR OVERALL (ECOLOGICAL) IMPACT ON THE WORLD IN OUR DAILY WORK.



CREDITS AND THANKS//

PHOTOGRAPHY

Ale Di Lullo
Baschi Bender
Manfred Stromberg
Martin Jacobsen
Matt Brooks
Marco Schmidt
Nadine Seuss
Philipp Herfort
Thomas Griesbeck
Syo van Vliet

PRODUCT PHOTOGRAPHY

DDB Photography

DESIGN SUPPORT

Konrad Lohöfener

P
R
L

Manfred Stromberg
Kurt Sorge
PERU